

**IMRITA**  
WHOLE HOUSE WATER FILTRATION SYSTEM

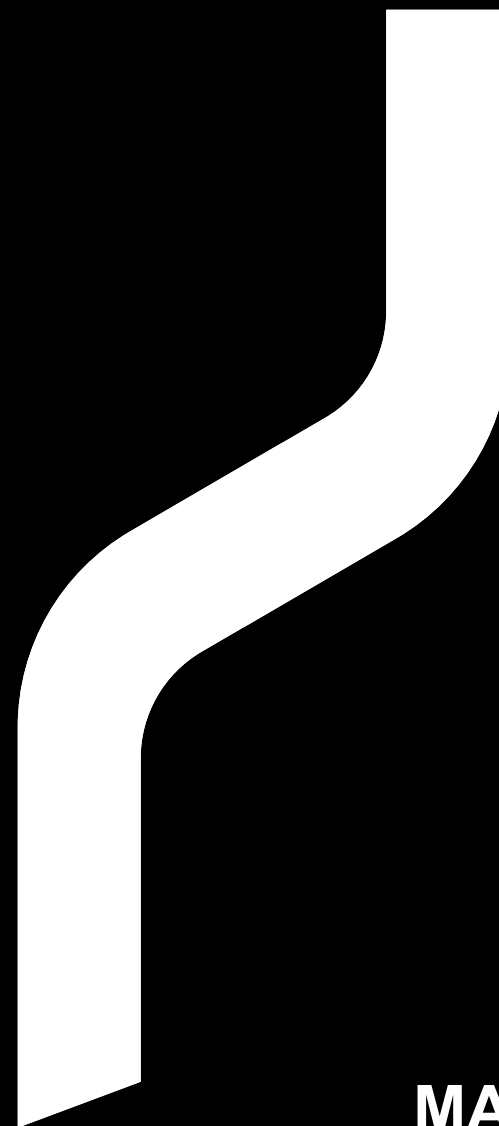

**MANUAL**  
**IMT-U7/U8**

**SHENZHEN IMRITA TECHNOLOGY CO., LTD**  
ADD: 301,302,401,402,501,502, Building B4a, Yingzhan  
Industrial Park, Longtian Community, Kengzi Subdistrict,  
Pingshan New District, Shenzhen.  
Tel: +86-0755-8966-9886 | Web: [www.imrita.com](http://www.imrita.com)

MADE IN CHINA

## THANKS

Thanks very much for choosing IMRITA brand, and be the user of IMRITA.

Before the machine installation, we suggest you to read this manual carefully.

If you have any questions during use, please read this manual carefully or contact us directly.

Email: [export10@imrita.com](mailto:export10@imrita.com)

Tel: +86 0755 89669886

Fax: +86 0755 8966 9907

Your valuable comments on our products and services are most welcome.

## TABLE OF CONTENTS

<b>The principle of performance</b> .....	1
Structure diagrams.....	1
Function & feature.....	1
Product parameters.....	2
Life service for filter cartridge.....	2
Water Production Principle.....	2
Flush Principle.....	3
<b>Installation</b> .....	3
Installation notice.....	3
Installation steps.....	4
<b>Usage &amp; maintenance</b> .....	6
First use.....	6
Daily Use.....	6
Usage Notice.....	7
Storage Notice.....	7
Filter Cartridge Replacement.....	8
Malfunctions and handling.....	8
<b>APPENDIX</b> .....	9
Ultra filtration membrane technology.....	9
Filtration Principle of ultra filtration membrane.....	9
<b>Packing list</b> .....	10

## THE PRINCIPLE OF PERFORMANCE

### Structure Diagrams

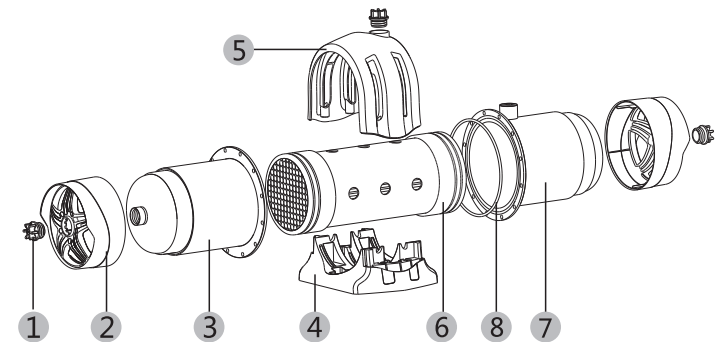

- |                |                    |                           |                |
|----------------|--------------------|---------------------------|----------------|
| 1 End cap      | 2 Cover            | 3 Stainless steel housing | 4 Base bracket |
| 5 Base bracket | 6 Filter cartridge | 7 Stainless steel housing | 8 Sealing ring |

Pic. 1 Structure Diagrams

### Function & Feature

#### Clean and healthy

High precision ultra filtration membrane screening and filtration technology, filtration accuracy up to 0.01 micron; Removal of sediment, rust, colloid and pathogenic bacteria are in line with the relevant national standards, while retaining beneficial minerals and trace elements in the water.

#### Long service life

Long service life of filter cartridge, modified PAN membrane formula, hydrophilic, strong pollution resistance; Mirror film making process, high surface finish, stain resistance and easy to wash; Frequent washing, timely exclusion of trapped pollutants, prolong the service life.

#### Super large water flow

Adequate design of water purification flow, fully meet the needs of the whole house water villa large duplex family.

#### Solid and durable

304 stainless steel housing grinding process, water hammer dynamic pressure, static pressure, blasting test higher than the industry standard.

#### Easier installation

Exquisite horizontal support, easily put the water purifier on the horizontal place, also wall hanging installation.

## Product parameters

Product Name: Central Ultra Filtration Water Purifier	
Item No.: IMT-U7	Filter type: Ultra Filtration Membrane
Filtration Accuracy: 0.01µm	Flow Rate: 3m³/h
Inlet Pressure: 0.1-0.4MPa	Temperature: 5°C-38°C
Application: Municipal Tap Water	Product Size: 549x277x262(mm)

Product Name: Central Ultra Filtration Water Purifier	
Item No.: IMT-U8	Filter type: Ultra Filtration Membrane
Filtration Accuracy: 0.01µm	Flow Rate: 4m³/h
Inlet Pressure: 0.1-0.4MPa	Temperature: 5°C-38°C
Application: Municipal Tap Water	Product Size: 679x277x262(mm)

## Life service for filter cartridge

With the long-term use of the water purification system, the water flow will gradually decline, please replace the filter cartridge regularly in order to ensure the water flow reaching the standard.

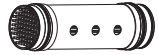
Type	Filtration accuracy	Material	Suggest to replace(months)	Qty (pcs)	Parts diagram
Ultra Filtration Membrane	0.01	PAN	24-36	1pc	

## Water Production Principle

Turn off the sewage port when in water production, as pic.2 shows: the source water (tap water) flows via inlet, then flows through ultra filtration membrane to intercept the sands, rust, colloid, pathogenic bacteria, etc. Also retaining the original minerals and trace elements in the water at the same time, and the purified water comes out from the outlet.

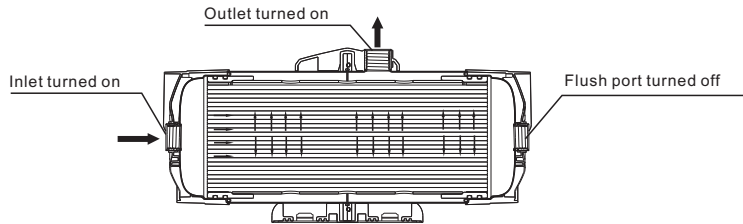

Pic. 2: water production principle

## Flush Principle

During the use of the water purification system, the pollutants left by the adsorption and load of the membrane are collected in the water purification system (attached to the inner surface of the ultra-membrane). If not discharged in time, it will be easy to make the water purification system become a secondary pollution. At the same time, the water production of the water purification system is continuously decreased due to the contamination attached to the surface of the ultra filtration membrane and blocked the micro pores of the ultra filtration membrane, so that the water purification system should be flushed during the period to extend the service life of the water purification system.

When the flush valve is turned on, outlet is turned off, the system is under the flushing state; The tap water flows in through the water inlet, and the water directly rushes through the ultra filtration membrane to the sewage outlet, flushing off the pollutants attached to the wall of the ultra filtration membrane and discharging away through the sewage outlet.

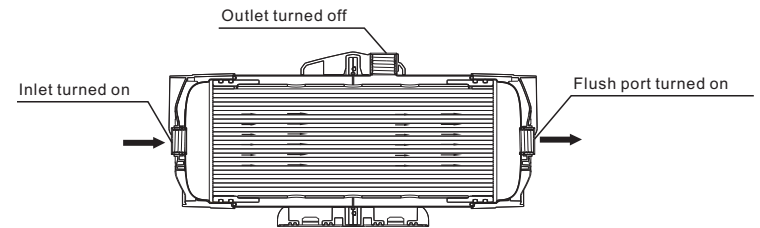

Pic.3 flush principle

## INSTALLATION

### Installation Notice

In order to make the water purification system meet the requirements of water quality and demand, the water quality, inlet pressure, inlet flow and inlet temperature of the water purification system should meet the requirements of parameters in the table.

- 1, If the inlet water quality is not municipal tap water, a pre filter filtration system needs to be added.
- 2, If the inlet water pressure is too low, less than 0.1mpa for a long time, it is necessary to install a booster pump (as shown in pic 4).

#### Note:

- a. When the inlet pressure is above 0.1Mpa, turn on the inlet valve V1, by pass valve V2, turn off the valve V3, to make the tap water not flowing through the booster pump.
- b. When the inlet pressure is lower than 0.1Mpa, turn on the inlet valve V1, the valve V3, turn off the by pass valve to make the tap water flowing through the booster pump (as shown in pic.4).

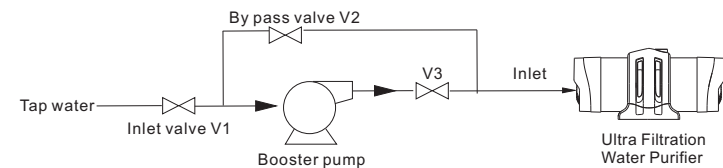

Pic. 4 booster pump installation diagram

3, If the inlet water pressure exceeds 0.4mpa, a pressure reduce valve should be installed for decompression.

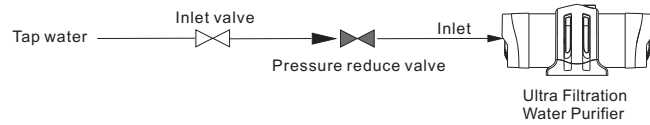

Pic. 5 pressure reduce valve installation diagram

2) Installation of other positions.

Generally speaking, the installation position of water purification system can be arranged in the other position of household water mains (such as toilet, balcony, pipeline well), and the size of main pipe is 1 inch or 3/4" tubing below the case, most of the PPR tubing or PE tubing flame connection method for pipeline and joint connection.

- Take down the end cap of water inlet, water outlet and flush port of water purification system.
- Install a fitting to connect the pipeline with the water purification system, as shown in pic.
- Install a by pass line between the inlet valve and outlet valve, and install by pass valve.
- Pipeline connection as shown in pic. 8.

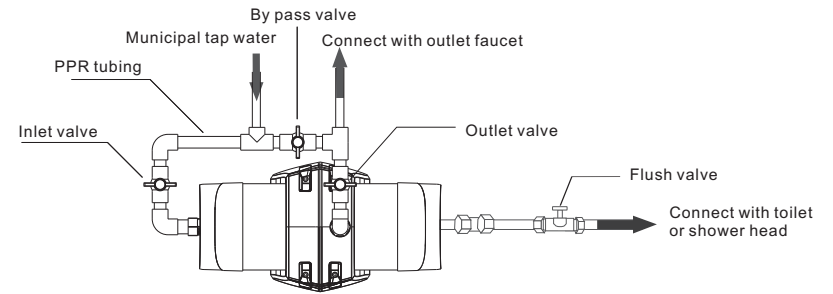

Pic.8 PPR tubing installation diagram

### 3.Fixed water purification system

- If it is installed on the ground, there is no need to fix it, just place it flat on the ground.
- This water purification system could be use a special mounting bracket for installation; Fix the mounting bracket(which need to buy it separately) to the wall with expansion screws. Then put the system on the bracket(as shown in pic.9). Note: This scheme is preferred for wall-hanging installation.

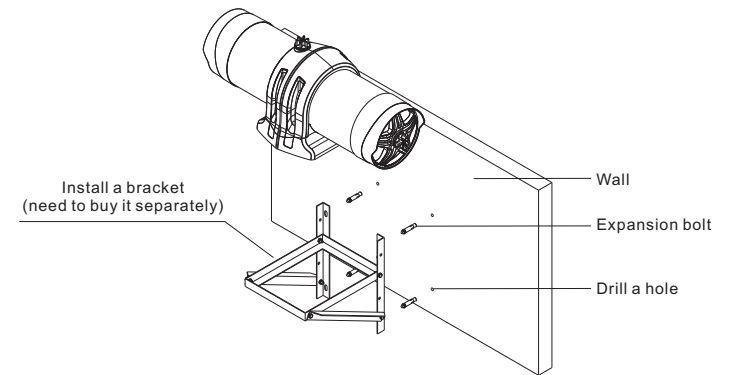

Pic. 9 bracket installation diagram

## Installation Steps

### 1.Checking the inlet water pressure.

Install a inlet valve on the inlet pipeline, use the pressure testing device to check the water pressure whether it between 0.1-04Mpa or not, as shown in pic. 6.

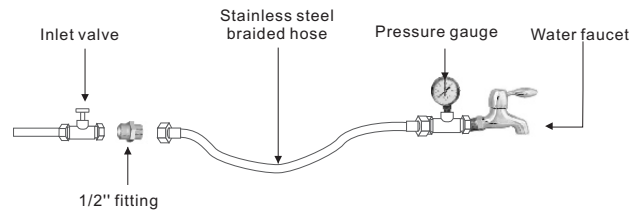

Pic.6 inlet water pressure checking diagram

### 2.Installation for fittings and pipeline

1) Under sink installation

In general (most cases), the main entrance into the kitchen after the 4 branch, because the cabinet space is limited, suitable for braided hose or bellow connected to the water purification system.

- Take down the end cap of water inlet, water outlet and flush port of water purification system;
- Connect the braided hose with inlet valve, and connect the outlet with the purification pipeline, flush port connect with the flush pipeline.
- The braided hose connection diagram shown in pic. 7 .

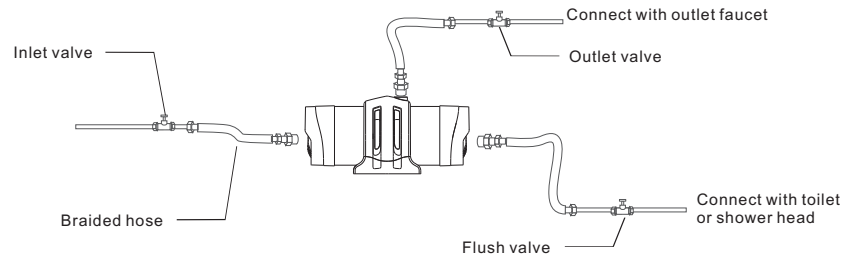

Pic. 7 the braided hose connection diagram

3) If you need to hang a wall to install, you need to first install board for to the appropriate installation position, and then on board the mounting holes on the bit drilling (including installation board side for horizontal installation, the other side for the vertical installation), after drilling the hole; Remove the cardboard, with self tapping screws to fix random matching installation is hanged in wall, then both hands hold up water purification system, Insert the clamp of the support of the water purification system into the mounting pendant and clamp it tightly. As shown in Pic. 10.

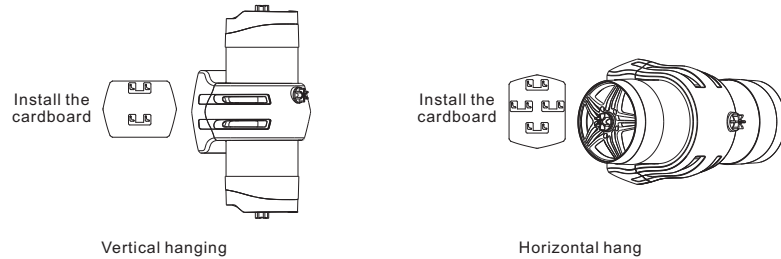

Pic. 10 installation diagram for water purification system

#### 4. Detection of water leakage

After installation, check each joint carefully for whether there is water leakage.

## USAGE & MAINTENANCE

### First Use

1. Please flush the central water filtration system when first use to flush the protective liquid of the membrane. Turn on the flush valve and inlet valve for flushing 20 minutes, till the water becomes clean.
2. In the process of flushing, turn on and off the flush valve frequently (off for 3 seconds, on for 10 seconds) to make the water flow form a pulsating impact, which will make the flushing effect better.
3. Turn off the flush valve, turn on the outlet valve for water production 15 minutes.

### Daily Use

1. When the accumulated water reaches 300 liters, it should be flushed: turn on the flush valve and turn off the outlet valve, then the water purification system can be flushed. The time of each flushing is about 30 seconds, so as to flush away the trapped pollutants, thus prolonging the service life.
2. Back flush to restore water flow: when the water flow of the water purification system is still less than the nominal value after flush, it should be back flushed to restore water flow. Back flushing of the water system can be realized by turning off the inlet valve, turn on the bypass valve and flushing port, as shown in pic. 11. Note: the arrow represents water flow), and repeat the steps of reverse flushing 3-5 times (if you have any questions, please contact the service center to provide back flushing service support).

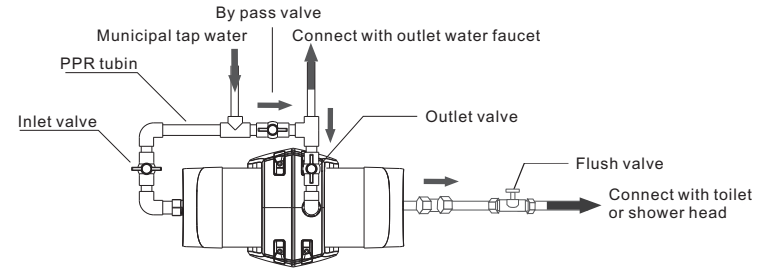

Pic. 11 back flush for water purification system

### Usage Notice

1. Frequent flushing can effectively prolong the service life of water purification system.
2. The rated total water volume of the water purification system has the relations with the inlet water quality; If the inlet water quality is better, the rated total net water will rise, on the contrary, if the water quality is poor, the rated total net water will decrease, the corresponding filter service life will be shorter.
  - 1) With the long-term use of the water purification system, the water flow will gradually decrease, but the water quality is still qualified.
  - 2) If the water purification system has not been used for more than three days, please flush it before reusing; It is recommended to manually flush for more than 10 times, then turn on the outlet valve 10 minutes for water production and discharge it.
  - 3) The water purification system should always keep the wetting state in the ultra filtration membrane after use. After the ultra filtration membrane filter element dries, the water production will sharply decrease and cannot be recovered.
  - 4) When going out for a long time (more than 1 day), make sure that the water inlet valve is turned off, so that the water purification system is in an unconfined state, which can prolong the service life of the water purification system and prevent unnecessary risk loss.
  - 5) Replacement of filter cartridge should be carried out by local retailer or under the guidance of local sale service professionals.
  - 6) When the water purification system fails, please immediately turn off the tap water inlet valve and turn off the outlet valve. Do not disassemble the water by oneself.
  - 7) Please call the customer service if find anything unusual or unknown in the process of using this water purification system.

### Storage Notice

1. Store in ventilated and cool place.
2. It can be sealed for one year before the first use. After one year, it should be re-sealed for sterilization. Please consult the customer service department for details.

## Filter Cartridge Replacement

If the water flow gradually decreases in the process of using the water purification system, and still cannot meet the requirements after repeated flushing and back flushing, the ultra filtration membrane filter cartridge needs to be replaced.

Replacement of filter cartridge(as shown in pic. 12)

- 1) Disassemble the screws and the bracket.
- 2) Disassemble the housing.
- 3) Take out the expired filter cartridge.(Need to push it)

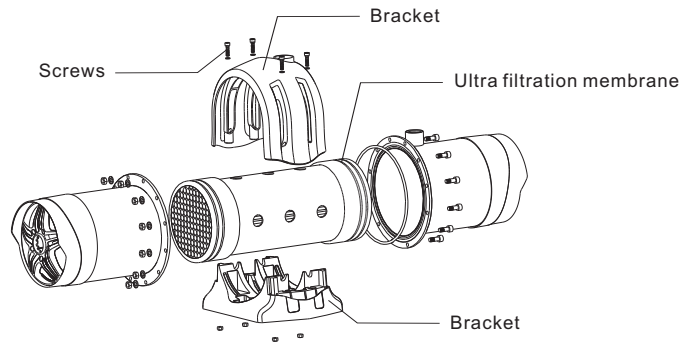

Pic.12 replacement of filter cartridge diagram

Note: the sealing ring should be checked. If the sealing ring is found to be scratched, notched, seriously distorted and deformed, the new sealing ring should be replaced to prevent leakage.

## Malfunctions and Handling

The following table is a list of possible malfunctions and their causes, please refer to their general troubleshooting methods.

Malfunction	Troubleshooting	Handling
Leakage of the water purification system	The sealing ring is damaged or aged.	Replace a new sealing ring
There is some off odor in purified water	The protective liquid remains when first use	Please flush the system according the first use requirement
	The system hasn't been using for a long time	Turn on the outlet or flush valve for flushing
The purified water flow decrease	The smell of tap water is too bad	Add an activated carbon filter cartridge
	Bad quality of the inlet water	Adopt pressurization measures
	The inlet pressure or flow is too low	Add a pre filter system
	The inlet temperature is to low	It is normal phenomenon

## APPENDIX

### Ultra filtration membrane technology

Ultra filtration membrane technology is a kind of ultra filtration membrane and the membrane pore size related to the size of the screening process, driven by the pressure difference on both sides of the membrane, ultra filtration membrane as the filter medium, under certain pressure, when the original fluid flow through the membrane surface, ultra filtration membrane surface with many tiny pores allow only water and small molecules through and become through the liquid, and concentrate in the volume is greater than the membrane surface micro aperture that substance is trapped At the inlet side of the membrane, it becomes concentrated liquid, thus achieving the purpose of purification, separation and concentration of the original liquid. Ultra filtration membrane separation technology, as one of the 21st century high and new technologies, has become a standard of separation process with its obvious characteristics of normal temperature, low pressure operation, no phase change and low energy consumption. It has been widely used in Europe and The United States and other developed countries and regions, and has become the mainstream technology of deep purification of drinking water. Ultra filtration membrane technology has replaced the traditional separation technology to a large extent to save energy, reduce consumption and improve separation quality.

### Filtration Principle of ultra filtration membrane

In the presence of pressure difference of the ultra filtration membrane on the both sides, when the water flow through the membrane surface, ultra filtration membrane surface with many tiny pores (per meter long ultra filtration membrane silk pipe distribution about 6 billion 0.01 micron pores) allow only water molecules and small molecules by beneficial minerals and trace elements, and the volume is greater than the pore diameter of materials (including sediment, rust, colloid, suspended matter, and pathogenic bacteria and other harmful substances) are intercepted, so as to achieve the purification of tap water. (As show in pic.13)

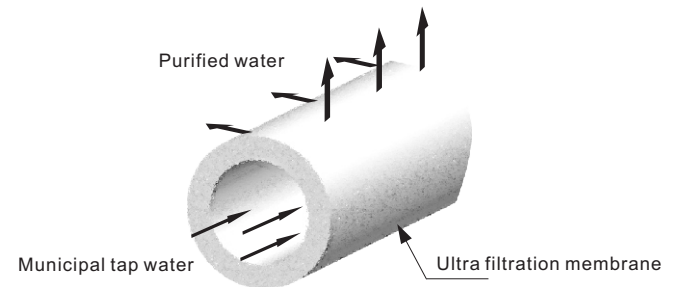

Pic. 13 Filtration Principle of ultra filtration membrane

## PACKING LIST

Central Ultra Filtration Water Purifier	Stainless steel mounting plate
86 N fitting	Self tapping screws kits
Manual	Hold drilling cardboard